

# Perspectives for the Irrigated Agriculture in Alentejo

RUI MANUEL DE SOUSA FRAGOSO\*, CARLOS A FALCÃO MARQUES\*

## 1. Introduction

In accordance with the recent orientations of the Common Agricultural Policy (CAP), over the last six years the Portuguese Government has included in the national agricultural policy guidelines the concern for the environment and natural resources, recognizing the multi-functionality of farmers in the countryside and promoting the integration of agricultural policy into rural development policy. However, the development of farms and the management of water resources for irrigation were defined as first objective in the implementation of public investment programs and incentives to private investment were set out to develop new irrigation projects and to update the existing ones (Fragoso, 2001).

Irrigated land in the Alentejo<sup>1</sup> amounts to 115.6 thousand hectares (INE, 1997). More than half of this area, about 62 thousand hectares, is included in public irrigated schemes. For the period 2000 to 2006, the government has planned to develop irrigation structures in Alentejo which will increase this area by more than 30 thousand hectares of new

## Abstract

The Portuguese government has planned to irrigate 30 thousand hectares of land in the Alentejo region within 2006. About 26 thousand hectares are part of the Alqueva Project. Irrigation is a potential solution to increase productivity and returns to agricultural resources. In general, economic results for irrigated crops are higher than for rainfed crops, even without CAP support. This paper anticipates the main trends and perspectives of irrigated agriculture in the Alentejo region with respect to production options, farm income and resource use and returns. The study is based on typical farms of the infrastructure 12, which is the first area of the Alqueva Irrigation Project to be implemented with almost 6 thousand hectares. The methodology used is based on a discrete stochastic programming model that maximizes the producers' expected utility. It is a farm level model which includes the main structural characteristics of farm types and irrigated agricultural production options as well as different types of years for crop water use and total availability for farmers. Results show that irrigated agriculture development is a potential option to promote agricultural competitiveness, incomes and resources returns of farmers that benefit from those public investments in irrigated structures in the Alentejo region.

## Résumé

*Le Gouvernement Portugais a décidé d'irriguer 30 mille hectares dans la région de l'Alentejo d'ici l'an 2006. Environ 26 mille hectares relèvent du projet de l'Alqueva. L'irrigation est une solution potentielle pour augmenter la productivité et le revenu agricole. En général les résultats économiques des cultures irriguées sont plus satisfaisants que ceux obtenus par les cultures pluviales, même si on ne considère pas les aides de la PAC. Cet article a pour but d'indiquer les principales tendances et perspectives d'évolution de l'agriculture irriguée dans la région de l'Alentejo concernant les options de production, le revenu, l'utilisation et la productivité des ressources agricoles. Cette étude est basée sur les exploitations type de la zone de l'infrastructure 12 du Projet d'Alqueva, avec environ 6 mille hectares irrigués. La méthode retenue pour cette analyse est un modèle stochastique de programmation mathématique, qui maximise l'utilité attendue du producteur. Ce modèle a été développé pour les exploitations type et il inclut leurs caractéristiques principales, leurs options de production irriguée et les différentes années pour la consommation d'eau par les cultures et la disponibilité d'eau pour les agriculteurs. Les résultats montrent que le développement de l'agriculture irriguée pourra être une solution potentielle pour promouvoir la compétitivité, le revenu agricole et la rentabilité des ressources pour les exploitations qui bénéficient de ces investissements publics dans les périmètres irrigués de la région de l'Alentejo.*

irrigated land. About 26 thousand hectares are integrated in the Alqueva Project<sup>2</sup>. This is a regional development project that is supposed to irrigate 110 thousand hectares of the best soils in Alentejo, during the next 25 to 30 years. The strategic objective is to create structural conditions to replace traditional agricultural dry land productions (cereals, sunflower, pastures and fodder plants) for a diversified range of irrigated crops in order to promote agricultural competitiveness and regional development.

Irrigation is intended to be a potential solution to increase productivity and return levels to agricultural resources in current and future economic and institutional settings. Economic results of irrigated crops are higher than those of dry land crops. Table 1 presents values for Profits / Costs relationship for different crops. They are particu-

larly favorable for industrial crops and fruits and vegetables. These crops remain competitive without benefiting from CAP support. The Value of the Production / Costs ratio is always above one.

This paper addresses the evolution of irrigated agriculture in the Alentejo region with respect to production options, farm incomes and returns to farm resources. Analysis is based upon typical farms of infrastructure 12 of the Alqueva Irrigation Project. This infrastructure includes about 5.9 thousand hectares of irrigated land in the Low

\* Management Department of Évora University

<sup>1</sup> A region in the South of Portugal.

<sup>2</sup> A regional multi-objective enterprise dealing with irrigation, production of hydro electricenergy and supplying water for urban consumption.

Table 1. Returns to selected Dry and Irrigated Crops

Crops	Production (T/ha)	Value of Production (Eur/há)	Profits/ Value of Production (Eur/Eur)	Value of Production/ Costs (Eur/Eur)	Profits/ Costs (Eur/Eur)
Dry traditional Crops					
Soft Wheat	2.2	78.9	1.79	0.69	1.23
Durum Wheat	2.0	92.9	2.09	0.81	1.69
Barley	1.9	65.5	1.73	0.66	1.13
Oats	1.6	59.3	1.50	0.66	0.99
Sunflower	0.6	26.3	2.95	0.38	1.12
Irrigated traditional Crops					
Soft Wheat	3.8	129.5	1.81	0.63	1.13
Durum Wheat	3.8	167.5	1.72	0.81	1.39
Corn	8.6	234.8	1.63	0.78	1.27
Sunflower	2.2	96.6	2.12	0.55	1.18
Irrigated Industrial Crops					
Sugar beet	45.0	441.0	1.05	1.81	1.91
Tomato	75.0	825.0	1.69	1.34	2.27
Pepper	30.0	1050.0	1.00	1.24	1.24
Irrigated Fruits and Vegetables					
Melon	22.0	1100.0	1.00	1.91	1.91
Potato	27.0	594.0	1.00	1.92	1.92
Onion	19.8	792.0	1.00	1.13	1.13
Lettuce	22.0	1320.0	1.00	1.23	1.23

Source: Fragoso, 2001.

Alentejo zone of Ferreira of Alentejo. It is the second phase of Odivelas<sup>3</sup> irrigation project. Its study is of great importance in anticipating direct economic effects of irrigated agriculture development in the Alentejo because it is the first infrastructure of Alqueva Irrigation Project which is expected to operate in the next future (2006-2007).

The agricultural area of Infrastructure 12 of the Alqueva Irrigation Project is characterized by a Mediterranean climate, clay and calcareous soils with high production potential, but scarce water resources. In the zone, the road infrastructure is good and links the main urban centers of the region to Lisbon and Spain. Some processing and trading units of agricultural products are installed in the zone. Major farmers' associations respect a water management. Most farmers are older than 45 years, with some experience in irrigated crops and show some dynamism which is well reflected by the high financial demand for agricultural investment in the last years (Coelho et al., 1998). Farm types vary, with three sub-zones of small and medium family-run farms as well as large farms (Fragoso, 2001).

This paper is structured into three parts. The next chapter refers to the methodology. In the following section some major results are presented and examined, followed by the conclusions in the last part.

<sup>3</sup> It's an irrigation project initiated in the seventies.

## 2. Methodology

When the objective is to evaluate and anticipate the effects and impacts of new policies at farm level, mathematical programming models have proven to be a particularly useful tool (Marques, 1988). Mathematical programming models respond to public investment in new irrigation projects. These models assume that decisions are economically rational and subject to restrictions that represent scarcity and changes in the resource availability, such as irrigated land due to new water endowments.

Stochastic mathematical programming models incorporate elements of risk of uncertainty in resource availability and adjustment of input-output coefficients, which are function of system states (Hardaker et al., 1997). These features are particularly useful in the Mediterranean conditions where variability of water availability and potential losses in crop productions are more important between years than within the year. In regions subject to such conditions, the major source of uncertainty is irrigation water use conditions due to a succession

of dry years, that can occur with relatively high frequency.

Mathematical programming with probabilistic restrictions has been used in the analysis of economic and management problems of irrigated land. Maji and Heady (1978) analyzed alternative management water policies for agricultural use under uncertainty conditions. Through the dynamic modeling with probabilistic restrictions, Eisel (1972) also analyzed irrigation infrastructure management. Taylor and Young (1995), using discrete sequential stochastic programming model, showed that farmers' benefits increase along with the guarantee of water availability.

Programming with probabilistic restrictions does not indicate the path to follow when the probability is violated (Cocks, 1968). This type of model handles the problem in a static way because it does not simulate sequential decisions that are taken in reality. Discrete stochastic programming suggested by Cocks and developed later by Rae (1971) handles jointly diverse sources of risk. It reproduces the farmer's decision-making process facing uncertainty of resource availability. Technical coefficients of production activities can be adjusted as function of needs and available resources, such as water for irrigation, in different decision states.

Public investment in new irrigation projects in the Alentejo region allows for a new range of agricultural pro-

Fig. 1. Decision Tree

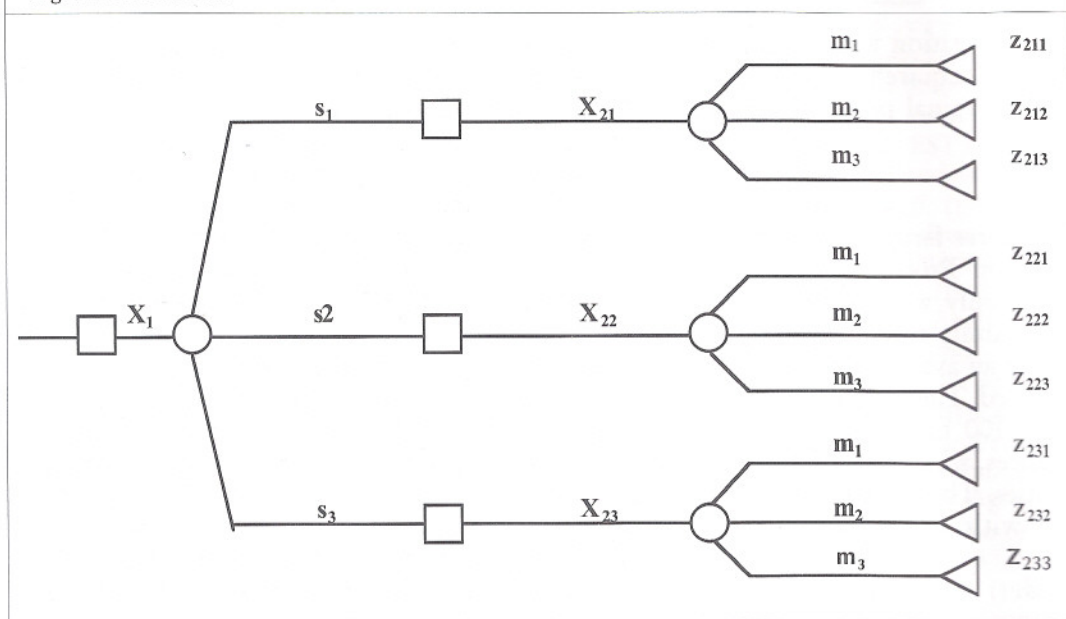

where:  $P_s$  and  $P_m$  are occurrence probabilities for each state of water use conditions  $s$  and market  $m$ ;  $U(Z_{s,m})$  is the expected utility as a function of farm income  $Z$  in the states of nature  $s$  and  $m$ ;  $p_{j,m}$  is the price of product  $j$  in state  $m$ ;  $f_{j,s}$  is the unit surface production function of product  $j$  in the state  $s$ ;  $k_{j,s}$  is a vector of variable inputs applied to crop  $j$  and state  $s$  per surface unit;  $a_{j,s}$  is the amount of water applied to crop  $j$  and state  $s$  in volume per surface unit;  $c_k$  is the unitary cost of variable inputs applied without water;  $c_a$  is the unitary cost of water per volume;  $c_x$  is

duction options. Farmers can choose traditional rainfed crops (cereals, sunflower, pastures and fodder plants) and / or irrigated crops (cereals, sunflower, pastures and fodder plants, industrial crops and fruits and vegetables). Choices are conditioned by available resources, such as total and irrigated land, capital, availability and use of water.

The problem with farmer's decision can be represented in a simplified form by the decision tree presented in Figure 1.

In the beginning of each agricultural year, farmers make production plan decisions, such as the area allocated to each crop based on the expected water use conditions and market price levels. Decisions are taken in an uncertainty environment. Later, as the farmer knows the effective available water for irrigation and crop needs, they adjust their decisions also taking into account probable sale price levels.

To model this decision problem, a discrete stochastic programming model was set to maximize the producer's expected utility. This model is based on Fragoso (1996), Jacquet and Pluvinage (1997) Keplinger et al. (1998), and Blanco (1999). Its simplified mathematical formula is as follows:

$$\begin{aligned} \text{Max } E[U] &= \sum_s \sum_m P_s P_m U(Z_{s,m}) \\ \text{s.a. } Z_{s,m} &= \\ &= \sum_j [p_{j,m} f_{j,s}(k_{j,s} a_{j,s}) - c_k k_{j,s} - c_a a_{j,s} - c_x] x_{j,s} \quad \forall s \in m \\ \sum_j x_{j,s} &\leq S \quad \forall s \\ \sum_j a_{j,s} x_{j,s} &\leq q_s \quad \forall s \\ x_{j,s} &\geq 0; k_{j,s} \geq 0; a_{j,s} \geq 0; e F \geq 0 \end{aligned}$$

the irrigation tax cost per surface unit;  $S$  are the available resources on the farm;  $q_s$  is the volume of available water in the state  $s$ ; and  $x_{j,s}$  is the area of the crop  $j$  in the state  $s$ .

Following Hardaker et al. (1997), the following utility function was used:

$$U(Z) = -0.157 + 0.257 \ln(Z + W_0 + 1.769)$$

where  $Z$  is the farm income and  $W_0$  represents the initial wealth. The logarithmic function is appropriate to represent risk adverse individual behavior in a normal degree, with relative risk aversion coefficient  $r_r(W) = 1$ .

The model represents an average year of farm economic activity. Its solution describes adjustments of farm structure in the long- and short-run decisions for agricultural market expected prices and water use conditions. The utility attribute function is the farm income that represents return to own factors.

The model includes investments in irrigation equipment for different technologies, grouped activities of plant production in irrigated and dry land, beef and sheep production and purchase of goods and services. Agricultural activities are broken down per crop, irrigation technology and state of water use conditions.

Restrictions of the model are land, capital, labor, irrigation water, pastures and fodder production. Land is divided in total and irrigated available land. Water used in irrigated land is determined per state of nature in accordance with the availability and with the level of losses in the crops. Labor is divided in family and wage labor, and constraints are implemented through restrictions per period in accordance to the agricultural calendar and state of water use. A similar procedure was adopted for financial restrictions in the short run. In the long run, financial

constraints and investments in fixed capital were included in annual average terms.

Resource availability of land and irrigation water is exogenous. Remaining resources can be acquired at market prices according to their value of marginal productivity levels.

### 3. Results

The model was implemented for three farm types of infrastructure 12 of Alqueva Irrigation Project: i) Farms with an average area of 7 hectares, only with plant production. They represent the small family-run farms with less than 20 hectares; ii) Farms with an average area of 45 hectares, where sheep is usually reared. These are medium family-run farms between 20 and 100 hectares; and iii) Farms with an average of 310 hectares, where cattle breeding is also one of the main activities. These are the large farms or agricultural holdings with more than 100 hectares.

Three scenarios were considered:

- i) Scenario 1 - without project, considering prices and compensatory payments and subsidies of CAP 2006;
- ii) Scenario 2 - with project, considering prices and compensatory payments and subsidies of CAP 2006;
- iii) Scenario 3 - with project, considering trade liberalization (no compensatory payments and subsidies were considered).

In scenarios with project, farmers are expected to pay public investment relatively to secondary network of wa-

ter distribution, management, maintenance of water pumping costs from primary network. Considering 50 years as useful life and an average water availability of 7400 m<sup>3</sup>/ha, an annual cost of water is estimated at 712.7 Euros/ha (0.10 Euros/m<sup>3</sup>).

Optimal production plan, farm income, resources use and resources returns are presented in Table 2. Returns to resources were calculated following land average returns and global factor returns (Barros and Estácio, 1972), labor average returns (Avillez, 1988) and water additional average benefits (Young, 1996; Blanco, 1999; and Frago, 2001). This last indicator measures the average upgrade of farm income from water use with project situation.

As for the results of scenario 1 without project, most of the area (more than 80%) is cultivated with rainfed crops. With the Alqueva Irrigation Project (scenario 2), irrigated land represents 66% in small family-run farms, 90% in medium family-run farms and 75% in the large farms of the overall area. In the first case, industrial crops (30%), fruits and vegetables (30%) are the most important crops. In the other two farm types, these crops represent 27 and 24% of the total area and the traditional irrigated crops represent 33 and 23%, respectively.

Substitution of dry land crop for irrigated areas leads to increases in income and resource returns.

For small family farms, income rises from 435 Euros/ha without project (scenario 1) up to 1213 Euros/ha with project (scenario 2). Global factor returns, land average returns and labor average returns increase from 0.91, -55 and 5195 to 1,03 Euros/Euro, 230 Euros/ha and 7190 Euros/UTA, respectively.

Table 2. Main Models Results by Farm Type and Scenario

	Small Family Farms Land = 7 ha			Medium Family Farms Land = 45 ha			Large Farm Land = 310 ha		
	Scenario 1	Scenario 2	Scenario 3	Scenario 1	Scenario 2	Scenario 3	Scenario 1	Scenario 2	Scenario 3
Dry Surface (%)	88.9	34.0	0.0	84.8	10.4	21.6	83.4	24.9	32.3
Irrigated Surface (%)	11.2	66.0	60.0	15.2	89.6	78.4	16.3	75.1	67.7
Irrigated Traditional Crops (%)	2.6	6.0	0.0	3.9	33.1	23.8	4.4	23.8	19.6
Irrigated Industrial Crops (%)	4.3	30.0	30.0	5.3	27.3	27.3	5.5	24.0	24.0
Irrigated Fruit and Vegetables	4.3	30.0	30.0	5.3	27.3	27.3	5.5	24.0	24.0
Irrig. Past. and Fodder Plants (%)	0.0	0.0	0.0	0.6	1.8	0.0	0.8	3.4	0.14
Farm Income (Eur/ha)	435	1213	1833	418	850	720	384	734	573
Labor (ha/UTA)	14.0	5.6	3.4	37.2	14.9	11.4	49	17.8	13.9
Water (m <sup>3</sup> /ha)	6641	7374	7155	5858	6454	7371	5600	6066	7351
Capital (Eur/ha)	555	2170	3240	460	2033	2306	534	1892	2090
Global Factor Returns (Eur/ha)	0.91	1.03	1.00	1.35	1.25	1.16	1.49	1.3	1.20
Land Average Returns (Eur/ha)	-55	230	125	270	660	485	345	685	510
Labor Ave Returns (Eur/UTA)	5195	7190	6675	15060	15185	11345	21370	17415	12815
Water Adtt. Av. Benef. (Eur/m <sup>3</sup> )	-	0.22	0.28	-	0.18	0.15	-	0.18	0.14

Source: Mathematical programming models results.

In medium family-run farm, the income for scenario 1 is estimated at 418 Euros/ha. With the project (scenario 2), that income doubles (850 Euros/ha). Land average returns increase three times, from 270 to 660 Euros/ha in scenario 2. Global factor returns drop by 10% almost and the labor average returns remain at the same level.

Large farms also experience increases in income and in returns to land from 384 and 345 Euros/ha (scenario 1) to 734 and Euros/ha (scenario 2). On these farms, global factor returns and labor average returns are lower with the project than without project because of the high increases in the resources use.

Full trade liberalization results (scenario 3) lead to production plans with the same trends as scenario 2, with income and land average returns increases lower than in scenario 2. However, they are still higher than the respective values without project. In this scenario for small family-run farms rainfed crops are abandoned; these farms are specialized in industrial crops, fruits and vegetables.

Global factor and labor returns do not increase in medium family-run farms and in large farms, because there are substantial increases in investment and labor use. In the first case, investments rise from 460 up to 2000 Euros/ha and in the second from 534 to 1892 or 2090 Euros/ha. Labor use increases from 37.9 to 14.9 or 11.4 ha/UTA and from 49 to 17.8 or 13.9 ha/UTA, respectively.

Water availability with the project implementation increases consumption levels. Additional benefits from water promoted for Alqueva Irrigation Project are estimated to vary according to different scenarios and farm types between 0.14 and 0.28 Euros/m<sup>3</sup>. These values are higher than the average water costs supported by farmers.

#### 4. Conclusion

This paper analyzes the evolution perspectives of irrigated agriculture in the Alentejo region. It is based on the case study of typical farms of infrastructure 12 of Alqueva Irrigation Project. A stochastic programming model with an utility function that maximizes the producers' expected utility was developed to simulate the decision process and represents major structural characteristics and constraints of different farm types.

Results show that irrigated agricultural development in the Alentejo region will be based on industrial crops, fruits and vegetables. Traditional irrigated crops still contribute to positive economic results particularly in medium and large farm types. However, an agricultural production model oriented towards industrial crops and fruit and vegetable production can increase significantly land and labor productivity. Farm incomes are expected to increase in irrigated areas.

Additional average water benefits are higher than average water costs supported by farms. Irrigated agricultural development in Alentejo is an investment option to promote farm incomes, resource returns and agricultural competitiveness of the region.

#### References

- AVILLEZ, F.; ESTÁCIO, F.; NEVES, M.C. (1988) : *Análise de Projectos Agrícolas no Contexto da Política Agrícola Comum*. Banco Pinto e Sotto Mayor, Imprensa Nacional - Casa da Moeda.
- BARROS, H.; ESTÁCIO, F. (1972): *Economia da Empresa Agrícola*: Universidade de Luanda, Nova Lisboa.
- BLANCO, M.F. (1999): *La Economía del Agua: Análisis de Políticas de Modernización y Mejora de Regadíos en España*. Universidad Politécnica de Madrid, Tesis doctoral, Madrid.
- CLEMEN, R.T. (1995): *Making Hard Decisions An Introduction to Decision Analysis*. Duxbeuy Press, 2<sup>a</sup> edition, USA.
- COCKS, K.D. (1968): *Discrete stochastic programming*. Management Science, 15, pp. 72-79.
- COELHO, J.C.; SILVA, L.M.; TRISTANY, M. (1998): *Análise da Segunda Fase do Perimetro de Rega de Odivelas*. Instituto Superior de Agronomia, Departamento de Produção Agrícola e Animal - Secção de Agricultura, Lisboa.
- EISEL, L. (1972): *Chance constrained Reservoir Model*. Water Resources Research, 8 (2), pp. 339-347.
- FRAGOSO, R.M.S. (1996): *Évaluation des impacts socio-économiques du développement de l'irrigation: le cas de l'agriculture dans la région de l'Alentejo*. CIHEAM-IAMM, Collection de Thèses et Masters IAMM, n.º 40, Montpellier.
- FRAGOSO, R.M.S. (2001): *Avaliação dos Impactos Sócio-Económicos de Plano de Rega de Alqueva no Sector Agrícola do Alentejo: o caso do bloco de rega da infra-estrutura 12*. Universidade de Évora, Dissertação de Doutoramento, Évora.
- HARDAKER, J.B.; HUIRNE, R.B.M.; and ANDERSON, J.R. (1997): *Coping with Risk in Agriculture*. CAB International, Wallingford.
- INE - INSTITUTO NACIONAL DE ESTATÍSTICA (1997): *Inquérito à Estrutura das Explorações Agrícolas - IEEA*.
- JACQUET, F.; PLUVINAGE, J. (1997): *Climatic Uncertainty and Farm Policy: A Discrete Stochastic Programming Model for Cereal-Livestock Farms in Algeria*. Agricultural Systems, 53, pp. 387-407.
- KEPLINGER, K.O.; MCCARL, B.A.; CHOWDHURY, M.E.; and LACEWELL, R.D. (1998): *Economic and Hydrologic Implications of Suspending Irrigation in Dry Years*. Journal Agricultural and Resource Economics, 23, pp. 191-205.
- MAJI, C.; and HEADY, E. (1978): *Intertemporal Allocation of Irrigation Water in the Mayurakshi Project (India): An Application of Chance Constrained Linear Programming*. Water Resources Research, 14 (2), pp. 190-205.
- MARQUES, C.A.F. (1988): *Portuguese Entrance into the European Community: Implications for Dry Land Agriculture in the Alentejo Region*. Purdue University, Ph.D. Dissertation, West Lafayette, Indiana.
- RAE, A.N. (1971): *An empirical application and evaluation of discrete stochastic programming in farm management*. American Journal of Agricultural Economics, 53, pp. 625-638.
- TAYLOR, R.G.; and YOUNG, R.A. (1995): *Rural-to-Urban Water Transfers: Measuring Foregone Direct Benefits on Irrigation Water Under Uncertain Water Supplies*. Journal of Agricultural and Resource Economics, 20 (2), pp. 247-262.
- YOUNG, R.A. (1996): *Measuring Economic Benefits for Water Investments and Policies*. World Bank Technical Paper Number 338, World Bank, Washington, DC.

